

Module LLE 24mm 1250lm HV ADV5

Modules LLE advanced



LLE 24x70mm 325lm HV ADV5



LLE 24x140mm 650lm HV ADV5



LLE 24x280mm 1250lm HV ADV5

Product description

- _ Ideal for linear and panel lights
- _ 2 terminals for serial wiring
- _ Perfectly uniform light, even if several LED modules are used together in a line
- _ Push terminals for quick and simple wiring of LED module to LED module
- _ Broad portfolio from extruded lenses and covers available
- _ HE ... High Efficiency, NM ... Nominal Mode, HO ... High Output
- _ Min. order quantity LLE 24x70mm QTY4: 36 pcs. The LLE 24x70mm QTY4 module contains 4 single 24x70mm modules which have to be separated
- _ Long lifetime up to 72,000 hours
- _ 5 years guarantee (conditions at <https://www.tridonic.com/manufacturer-guarantee-conditions>)

Optical properties

- _ Colour temperatures 2,700, 3,000, 4,000, 5,000 and 6,500 K
- _ Useful luminous flux 2,507 lm at Irated and tp = 25 °C
- _ Efficacy of the LED module 190 lm/W at Irated and tp = 25 °C
- _ High colour rendering index CRI > 80
- _ High colour consistency (MacAdam 3) ①
- _ Small luminous flux tolerances

Mechanical properties

- _ Module dimension 24 x 70 mm, 24 x 140 mm, 24 x 280 mm and 24 x 560 mm (ZHAGA compliant)
- _ Simple installation via clips or screws

System solution

- _ Combine Tridonic's LED modules and dimmable drivers to achieve an outstanding system efficacy (configuration possible via <https://setbuilder.tridonic.com/>)

① Integral measurement over the complete module.

Website

<http://www.tridonic.com/89603203>

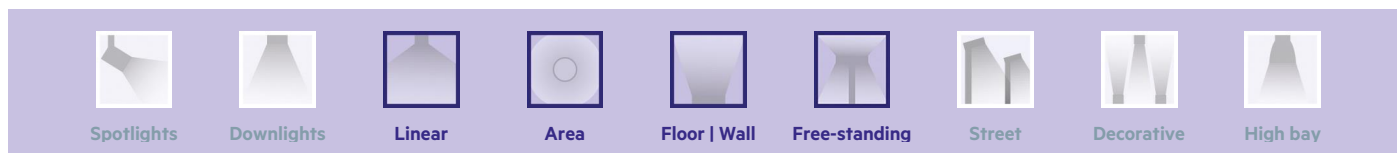
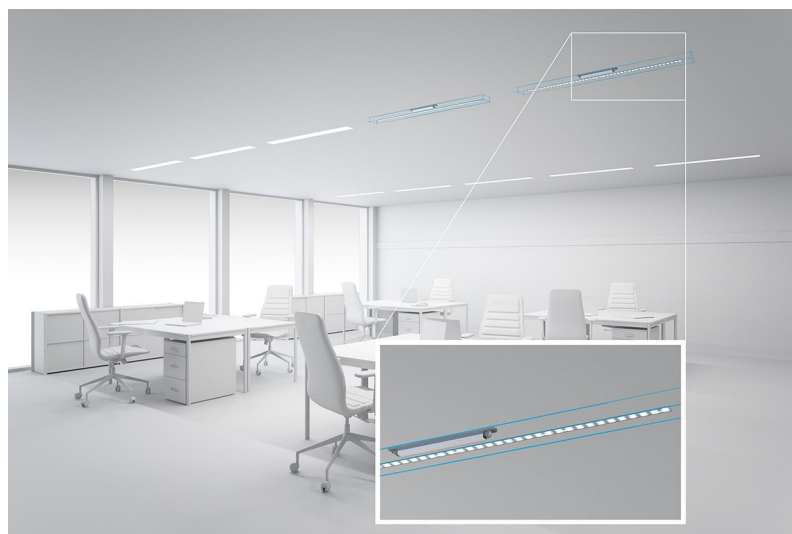

Module LLE 24mm 1250lm HV ADV5

Modules LLE advanced

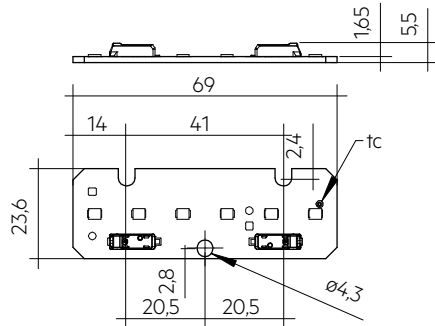

LLE 24x70mm 325lm HV ADV5

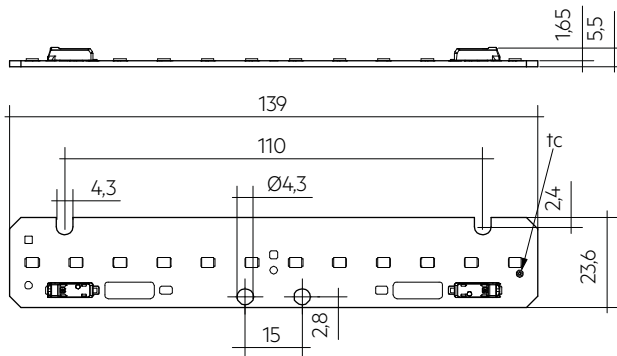

LLE 24x140mm 650lm HV ADV5

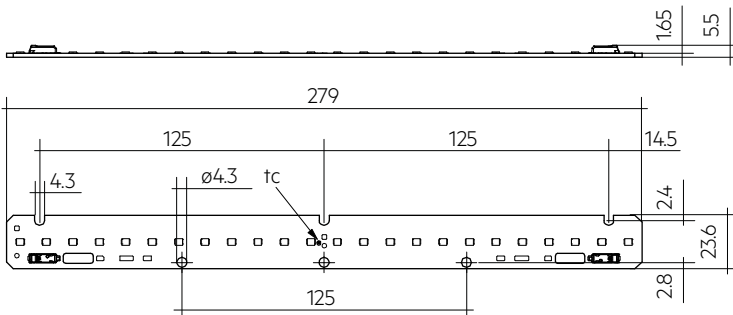

LLE 24x280mm 1250lm HV ADV5

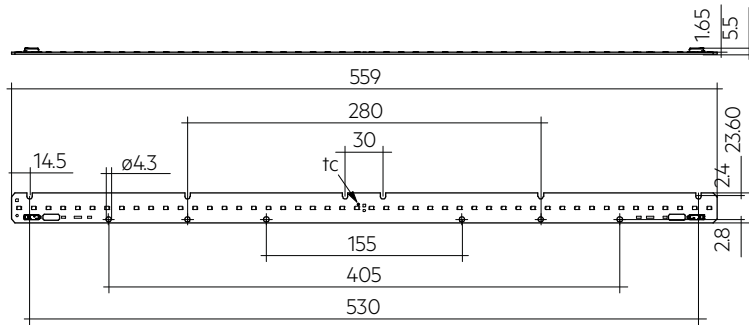

LLE 24x560mm 2400lm HV ADV5

Ordering data

Type	Article number	Colour temperature	Packaging, carton	Weight per pc.
LLE 24x70mm 325lm 830 HV ADV5 QTY4	89603203	3,000 K	108 pc(s).	0.022 kg
LLE 24x70mm 325lm 840 HV ADV5 QTY4	89603204	4,000 K	108 pc(s).	0.022 kg
LLE 24x70mm 325lm 850 HV ADV5 QTY4	28003379	5,000 K	108 pc(s).	0.022 kg
LLE 24x70mm 325lm 865 HV ADV5 QTY4	28002946	6,500 K	108 pc(s).	0.022 kg
LLE 24x140mm 650lm 830 HV ADV5	89603206	3,000 K	108 pc(s).	0.011 kg
LLE 24x140mm 650lm 835 HV ADV5	28003404	3,500 K	108 pc(s).	0.011 kg
LLE 24x140mm 650lm 840 HV ADV5	89603207	4,000 K	108 pc(s).	0.011 kg
LLE 24x280mm 1250lm 827 HV ADV5	89603210	2,700 K	108 pc(s).	0.023 kg
LLE 24x280mm 1250lm 830 HV ADV5	89603211	3,000 K	108 pc(s).	0.023 kg
LLE 24x280mm 1250lm 835 HV ADV5	28003405	3,500 K	108 pc(s).	0.023 kg
LLE 24x280mm 1250lm 840 HV ADV5	89603212	4,000 K	108 pc(s).	0.023 kg
LLE 24x280mm 1250lm 850 HV ADV5	89603213	5,000 K	108 pc(s).	0.023 kg
LLE 24x280mm 1250lm 865 HV ADV5	89603214	6,500 K	108 pc(s).	0.023 kg
LLE 24x560mm 2400lm 827 HV ADV5	89603215	2,700 K	108 pc(s).	0.040 kg
LLE 24x560mm 2400lm 830 HV ADV5	89603216	3,000 K	108 pc(s).	0.040 kg
LLE 24x560mm 2400lm 835 HV ADV5	28003262	3,500 K	108 pc(s).	0.040 kg
LLE 24x560mm 2400lm 840 HV ADV5	89603217	4,000 K	108 pc(s).	0.040 kg
LLE 24x560mm 2400lm 850 HV ADV5	89603218	5,000 K	108 pc(s).	0.040 kg
LLE 24x560mm 2400lm 865 HV ADV5	89603219	6,500 K	108 pc(s).	0.040 kg

Technical data

Beam characteristic	120°
Ambient temperature t_a	-40 ... +65 °C
t_p rated	50 °C
t_c	85 °C
I_{rated}	300 mA
I_{max}	540 mA
Max. permissible LF current ripple	595 mA
Max. permissible peak current	900 mA / max. 10 ms
Max. working voltage for insulation [®]	440 V
Insulation test voltage	1.88 kV
CTI of the printed circuit board	≥ 600
ESD classification	Severity level 4
Risk group (IEC 62471) at ≤ 470 mA	RG0
Risk group (IEC 62471) at I_{max}	RG1
Classification acc. to IEC 62031	Built-in
Type of protection	IP00
Lumen maintenance L70B50	72,000 h
Guarantee (conditions at www.tridonic.com)	5 Year(s)

Approval marks**Standards**

IEC 62031, IEC 62471, IEC 61000-4-2, IEC 62778, IEC 61547, UL 8750

Specific technical data

Type	Article number	Photometric code	Useful luminous flux at tp = 25 °C	Expected luminous flux at tp rated	Typ. forward current	Min. forward voltage at tp rated	Max. forward voltage at tp = 25 °C	Power consumption Pon at tp = 25 °C	Efficacy of the module at tp = 25 °C	Expected efficacy of the module at tp rated	Colour rendering index CRI
Operating mode HE at 200 mA											
LLE 24x70mm 325lm 830 HV ADV5 QTY4	89603203	830/359	-	207 lm	200 mA	5.2 V	5.6 V	-	-	184 lm/W	> >80
LLE 24x70mm 325lm 840 HV ADV5 QTY4	89603204	840/359	-	212 lm	200 mA	5.2 V	5.6 V	-	-	192 lm/W	> >80
LLE 24x70mm 325lm 850 HV ADV5 QTY4	28003379	850/359	-	211 lm	200 mA	5.2 V	5.6 V	-	-	189 lm/W	> >80
LLE 24x70mm 325lm 865 HV ADV5 QTY4	28002946	865/359	-	204 lm	200 mA	5.2 V	5.6 V	-	-	182 lm/W	> >80
LLE 24x140mm 650lm 830 HV ADV5	89603206	830/359	-	404 lm	200 mA	10.3 V	11.2 V	-	-	189 lm/W	> >80
LLE 24x140mm 650lm 835 HV ADV5	28003404	835/359	-	421 lm	200 mA	10.3 V	11.2 V	-	-	195 lm/W	> >80
LLE 24x140mm 650lm 840 HV ADV5	89603207	830/359	-	423 lm	200 mA	10.3 V	11.2 V	-	-	198 lm/W	> >80
LLE 24x280mm 1250lm 827 HV ADV5	89603210	827/359	-	788 lm	200 mA	20.7 V	22.4 V	-	-	181 lm/W	> >80
LLE 24x280mm 1250lm 830 HV ADV5	89603211	830/359	-	802 lm	200 mA	20.7 V	22.4 V	-	-	185 lm/W	> >80
LLE 24x280mm 1250lm 835 HV ADV5	28003405	835/359	-	841 lm	200 mA	20.7 V	22.4 V	-	-	192 lm/W	> >80
LLE 24x280mm 1250lm 840 HV ADV5	89603212	840/359	-	851 lm	200 mA	20.7 V	22.4 V	-	-	195 lm/W	> >80
LLE 24x280mm 1250lm 850 HV ADV5	89603213	850/359	-	850 lm	200 mA	20.7 V	22.4 V	-	-	195 lm/W	> >80
LLE 24x280mm 1250lm 865 HV ADV5	89603214	865/359	-	844 lm	200 mA	20.7 V	22.4 V	-	-	194 lm/W	> >80
LLE 24x560mm 2400lm 827 HV ADV5	89603215	827/359	-	1,547 lm	200 mA	41.4 V	44.8 V	-	-	180 lm/W	> >80
LLE 24x560mm 2400lm 830 HV ADV5	89603216	830/359	-	1,613 lm	200 mA	41.4 V	44.8 V	-	-	187 lm/W	> >80
LLE 24x560mm 2400lm 835 HV ADV5	28003262	835/359	-	1,644 lm	200 mA	41.4 V	44.8 V	-	-	190 lm/W	> >80
LLE 24x560mm 2400lm 840 HV ADV5	89603217	840/359	-	1,700 lm	200 mA	41.4 V	44.8 V	-	-	196 lm/W	> >80
LLE 24x560mm 2400lm 850 HV ADV5	89603218	850/359	-	1,693 lm	200 mA	41.4 V	44.8 V	-	-	196 lm/W	> >80
LLE 24x560mm 2400lm 865 HV ADV5	89603219	865/359	-	1,694 lm	200 mA	41.4 V	44.8 V	-	-	195 lm/W	> >80
Operating mode HE at 250 mA											
LLE 24x70mm 325lm 830 HV ADV5 QTY4	89603203	830/359	-	251 lm	250 mA	5.2 V	5.7 V	-	-	179 lm/W	> >80
LLE 24x70mm 325lm 840 HV ADV5 QTY4	89603204	840/359	-	260 lm	250 mA	5.2 V	5.7 V	-	-	187 lm/W	> >80
LLE 24x70mm 325lm 850 HV ADV5 QTY4	28003379	850/359	-	258 lm	250 mA	5.2 V	5.7 V	-	-	185 lm/W	> >80
LLE 24x70mm 325lm 865 HV ADV5 QTY4	28002946	865/359	-	251 lm	250 mA	5.2 V	5.7 V	-	-	179 lm/W	> >80
LLE 24x140mm 650lm 830 HV ADV5	89603206	830/359	-	502 lm	250 mA	10.4 V	11.3 V	-	-	184 lm/W	> >80
LLE 24x140mm 650lm 835 HV ADV5	28003404	835/359	-	516 lm	250 mA	10.4 V	11.3 V	-	-	190 lm/W	> >80
LLE 24x140mm 650lm 840 HV ADV5	89603207	840/359	-	501 lm	250 mA	10.4 V	11.3 V	-	-	191 lm/W	> >80
LLE 24x280mm 1250lm 827 HV ADV5	89603210	827/359	-	972 lm	250 mA	20.9 V	22.6 V	-	-	176 lm/W	> >80
LLE 24x280mm 1250lm 830 HV ADV5	89603211	830/359	-	991 lm	250 mA	20.9 V	22.6 V	-	-	180 lm/W	> >80
LLE 24x280mm 1250lm 835 HV ADV5	28003405	835/359	-	1,032 lm	250 mA	20.9 V	22.6 V	-	-	187 lm/W	> >80
LLE 24x280mm 1250lm 840 HV ADV5	89603212	840/359	-	1,040 lm	250 mA	20.9 V	22.6 V	-	-	190 lm/W	> >80
LLE 24x280mm 1250lm 850 HV ADV5	89603213	850/359	-	1,026 lm	250 mA	20.9 V	22.6 V	-	-	187 lm/W	> >80
LLE 24x280mm 1250lm 865 HV ADV5	89603214	865/359	-	1,032 lm	250 mA	20.9 V	22.6 V	-	-	189 lm/W	> >80
LLE 24x560mm 2400lm 827 HV ADV5	89603215	827/359	-	1,898 lm	250 mA	41.8 V	45.3 V	-	-	175 lm/W	> >80
LLE 24x560mm 2400lm 830 HV ADV5	89603216	830/359	-	1,982 lm	250 mA	41.8 V	45.3 V	-	-	182 lm/W	> >80
LLE 24x560mm 2400lm 835 HV ADV5	28003262	835/359	-	2,015 lm	250 mA	41.8 V	45.3 V	-	-	185 lm/W	> >80
LLE 24x560mm 2400lm 840 HV ADV5	89603217	840/359	-	2,094 lm	250 mA	41.8 V	45.3 V	-	-	191 lm/W	> >80
LLE 24x560mm 2400lm 850 HV ADV5	89603218	850/359	-	2,058 lm	250 mA	41.8 V	45.3 V	-	-	188 lm/W	> >80
LLE 24x560mm 2400lm 865 HV ADV5	89603219	865/359	-	2,086 lm	250 mA	41.8 V	45.3 V	-	-	190 lm/W	> >80
Operating mode HE at 275 mA											
LLE 24x70mm 325lm 830 HV ADV5 QTY4	89603203	830/359	-	270 lm	275 mA	5.3 V	5.7 V	-	-	175 lm/W	> >80
LLE 24x70mm 325lm 840 HV ADV5 QTY4	89603204	840/359	-	279 lm	275 mA	5.3 V	5.7 V	-	-	183 lm/W	> >80
LLE 24x70mm 325lm 850 HV ADV5 QTY4	28003379	850/359	-	276 lm	275 mA	5.3 V	5.7 V	-	-	180 lm/W	> >80
LLE 24x70mm 325lm 865 HV ADV5 QTY4	28002946	865/359	-	270 lm	275 mA	5.3 V	5.7 V	-	-	175 lm/W	> >80
LLE 24x140mm 650lm 830 HV ADV5	89603206	830/359	-	541 lm	275 mA	10.5 V	11.4 V	-	-	180 lm/W	> >80
LLE 24x140mm 650lm 835 HV ADV5	28003404	835/359	-	561 lm	275 mA	10.5 V	11.4 V	-	-	186 lm/W	> >80
LLE 24x140mm 650lm 840 HV ADV5	89603207	840/359	-	559 lm	275 mA	10.5 V	11.4 V	-	-	189 lm/W	> >80
LLE 24x280mm 1250lm 827 HV ADV5	89603210	827/359	-	1,051 lm	275 mA	21.0 V	22.7 V	-	-	172 lm/W	> >80
LLE 24x280mm 1250lm 830 HV ADV5	89603211	830/359	-	1,068 lm	275 mA	21.0 V	22.7 V	-	-	176 lm/W	> >80
LLE 24x280mm 1250lm 835 HV ADV5	28003405	835/359	-	1,122 lm	275 mA	21.0 V	22.7 V	-	-	183 lm/W	> >80
LLE 24x280mm 1250lm 840 HV ADV5	89603212	840/359	-	1,132 lm	275 mA	21.0 V	22.7 V	-	-	186 lm/W	> >80
LLE 24x280mm 1250lm 850 HV ADV5	89603213	850/359	-	1,116 lm	275 mA	21.0 V	22.7 V	-	-	182 lm/W	> >80
LLE 24x280mm 1250lm 865 HV ADV5	89603214	865/359	-	1,124 lm	275 mA	21.0 V	22.7 V	-	-	185 lm/W	> >80
LLE 24x560mm 2400lm 827 HV ADV5	89603215	827/359	-	2,053 lm	275 mA	42.0 V	45.5 V	-	-	171 lm/W	> >80
LLE 24x560mm 2400lm 830 HV ADV5	89603216	830/359	-	2,142 lm	275 mA	42.0 V	45.5 V	-	-	178 lm/W	> >80
LLE 24x560mm 2400lm 835 HV ADV5	28003262	835/359	-	2,187 lm	275 mA	42.0 V	45.5 V	-	-	181 lm/W	> >80
LLE 24x560mm 2400lm 840 HV ADV5	89603217	840/359	-	2,254 lm	275 mA	42.0 V	45.5 V	-	-	187 lm/W	> >80
LLE 24x560mm 2400lm 850 HV ADV5	89603218	850/359	-	2,214 lm	275 mA	42.0 V	45.5 V	-	-	184 lm/W	> >80
LLE 24x560mm 2400lm 865 HV ADV5	89603219	865/359	-	2,246 lm	275 mA	42.0 V	45.5 V	-	-	186 lm/W	> >80
Operating mode NM at 300 mA											
LLE 24x70mm 325lm 830 HV ADV5 QTY4	89603203	830/359	300 lm	295 lm	300 mA	5.3 V	5.7 V	1.70 W	176 lm/W	174 lm/W	> >80
LLE 24x70mm 325lm 840 HV ADV5 QTY4	89603204	840/359	313 lm	303 lm	300 mA	5.3 V	5.7 V	1.70 W	184 lm/W	180 lm/W	> >80
LLE 24x70mm 325lm 850 HV ADV5 QTY4	28003379	850/359	309 lm	300 lm	300 mA	5.3 V	5.7 V	1.70 W	182 lm/W	178 lm/W	> >80
LLE 24x70mm 325lm 865 HV ADV5 QTY4	28002946	865/359	308 lm	299 lm	300 mA	5.3 V	5.7 V	1.70 W	181 lm/W	177 lm/W	> >80
LLE 24x140mm 650lm 830 HV ADV5	89603206	830/359	599 lm	584 lm	300 mA	10.5 V	11.4 V	3.30 W	182 lm/W	179 lm/W	> >80
LLE 24x140mm 650lm 835 HV ADV5	28003404	835/359	621 lm	606 lm	300 mA	10.6 V	11.5 V	3.30 W	188 lm/W	184 lm/W	> >80
LLE 24x140mm 650lm 840 HV ADV5	89603207	830/359	627 lm	612 lm	300 mA	10.5 V	11.4 V	3.30 W	190 lm/W	186 lm/W	> >80

Type	Article number	Photometric code	Useful luminous flux Φ_v at $T_p = 25^\circ\text{C}$	Expected luminous flux Φ_v at T_p rated	Typ. forward current	Min. forward voltage at T_p rated	Max. forward voltage at $T_p = 25^\circ\text{C}$	Power consumption P_{on} at $T_p = 25^\circ\text{C}$	Efficacy of the module at $T_p = 25^\circ\text{C}$	Expected efficacy of the module at T_p rated	Colour rendering index CRI
LLE 24x280mm 1250lm 827 HV ADV5	89603210	827/359	1,160 lm	1,130 lm	300 mA	21.1 V	22.8 V	6.70 W	173 lm/W	170 lm/W	> >80
LLE 24x280mm 1250lm 830 HV ADV5	89603211	830/359	1,189 lm	1,160 lm	300 mA	21.1 V	22.8 V	6.70 W	177 lm/W	175 lm/W	> >80
LLE 24x280mm 1250lm 835 HV ADV5	28003405	835/359	1,242 lm	1,212 lm	300 mA	21.1 V	22.8 V	6.70 W	185 lm/W	181 lm/W	> >80
LLE 24x280mm 1250lm 840 HV ADV5	89603212	840/359	1,254 lm	1,225 lm	300 mA	21.1 V	22.8 V	6.70 W	187 lm/W	183 lm/W	> >80
LLE 24x280mm 1250lm 850 HV ADV5	89603213	850/359	1,254 lm	1,226 lm	300 mA	21.1 V	22.8 V	6.70 W	187 lm/W	183 lm/W	> >80
LLE 24x280mm 1250lm 865 HV ADV5	89603214	865/359	1,254 lm	1,219 lm	300 mA	21.1 V	22.8 V	6.70 W	187 lm/W	183 lm/W	> >80
LLE 24x560mm 2400lm 827 HV ADV5	89603215	827/359	2,287 lm	2,229 lm	300 mA	42.2 V	45.7 V	13.31 W	172 lm/W	169 lm/W	> >80
LLE 24x560mm 2400lm 830 HV ADV5	89603216	830/359	2,390 lm	2,322 lm	300 mA	42.2 V	45.7 V	13.31 W	180 lm/W	177 lm/W	> >80
LLE 24x560mm 2400lm 835 HV ADV5	28003262	835/359	2,436 lm	2,368 lm	300 mA	42.2 V	45.7 V	13.30 W	183 lm/W	179 lm/W	> >80
LLE 24x560mm 2400lm 840 HV ADV5	89603217	840/359	2,507 lm	2,439 lm	300 mA	42.2 V	45.7 V	13.31 W	188 lm/W	184 lm/W	> >80
LLE 24x560mm 2400lm 850 HV ADV5	89603218	850/359	2,507 lm	2,431 lm	300 mA	42.2 V	45.7 V	13.31 W	188 lm/W	185 lm/W	> >80
LLE 24x560mm 2400lm 865 HV ADV5	89603219	865/359	2,507 lm	2,439 lm	300 mA	42.2 V	45.7 V	13.31 W	188 lm/W	184 lm/W	> >80
Operating mode HO at 350 mA											
LLE 24x70mm 325lm 830 HV ADV5 QTY4	89603203	830/359	-	344 lm	350 mA	5.3 V	5.8 V	-	-	170 lm/W	> >80
LLE 24x70mm 325lm 840 HV ADV5 QTY4	89603204	840/359	-	347 lm	350 mA	5.3 V	5.8 V	-	-	177 lm/W	> >80
LLE 24x70mm 325lm 850 HV ADV5 QTY4	28003379	850/359	-	346 lm	350 mA	5.3 V	5.8 V	-	-	174 lm/W	> >80
LLE 24x70mm 325lm 865 HV ADV5 QTY4	28002946	865/359	-	336 lm	350 mA	5.3 V	5.8 V	-	-	171 lm/W	> >80
LLE 24x140mm 650lm 830 HV ADV5	89603206	830/359	-	672 lm	350 mA	10.6 V	11.5 V	-	-	175 lm/W	> >80
LLE 24x140mm 650lm 835 HV ADV5	28003404	835/359	-	701 lm	350 mA	10.7 V	11.5 V	-	-	181 lm/W	> >80
LLE 24x140mm 650lm 840 HV ADV5	89603207	840/359	-	705 lm	350 mA	10.6 V	11.5 V	-	-	183 lm/W	> >80
LLE 24x280mm 1250lm 827 HV ADV5	89603210	827/359	-	1,314 lm	350 mA	21.3 V	23.0 V	-	-	167 lm/W	> >80
LLE 24x280mm 1250lm 830 HV ADV5	89603211	830/359	-	1,339 lm	350 mA	21.3 V	23.0 V	-	-	171 lm/W	> >80
LLE 24x280mm 1250lm 835 HV ADV5	28003405	835/359	-	1,402 lm	350 mA	21.3 V	23.0 V	-	-	178 lm/W	> >80
LLE 24x280mm 1250lm 840 HV ADV5	89603212	840/359	-	1,410 lm	350 mA	21.3 V	23.0 V	-	-	180 lm/W	> >80
LLE 24x280mm 1250lm 850 HV ADV5	89603213	850/359	-	1,392 lm	350 mA	21.3 V	23.0 V	-	-	178 lm/W	> >80
LLE 24x280mm 1250lm 865 HV ADV5	89603214	865/359	-	1,399 lm	350 mA	21.3 V	23.0 V	-	-	179 lm/W	> >80
LLE 24x560mm 2400lm 827 HV ADV5	89603215	827/359	-	2,574 lm	350 mA	42.5 V	46.1 V	-	-	166 lm/W	> >80
LLE 24x560mm 2400lm 830 HV ADV5	89603216	830/359	-	2,686 lm	350 mA	42.5 V	46.1 V	-	-	173 lm/W	> >80
LLE 24x560mm 2400lm 835 HV ADV5	28003262	835/359	-	2,734 lm	350 mA	42.5 V	46.1 V	-	-	176 lm/W	> >80
LLE 24x560mm 2400lm 840 HV ADV5	89603217	840/359	-	2,833 lm	350 mA	42.5 V	46.1 V	-	-	182 lm/W	> >80
LLE 24x560mm 2400lm 850 HV ADV5	89603218	850/359	-	2,786 lm	350 mA	42.5 V	46.1 V	-	-	179 lm/W	> >80
LLE 24x560mm 2400lm 865 HV ADV5	89603219	865/359	-	2,822 lm	350 mA	42.5 V	46.1 V	-	-	181 lm/W	> >80
Operating mode HO at 400 mA											
LLE 24x70mm 325lm 830 HV ADV5 QTY4	89603203	830/359	-	393 lm	400 mA	5.4 V	5.8 V	-	-	170 lm/W	> >80
LLE 24x70mm 325lm 840 HV ADV5 QTY4	89603204	840/359	-	400 lm	400 mA	5.4 V	5.8 V	-	-	177 lm/W	> >80
LLE 24x70mm 325lm 850 HV ADV5 QTY4	28003379	850/359	-	398 lm	400 mA	5.4 V	5.8 V	-	-	174 lm/W	> >80
LLE 24x70mm 325lm 865 HV ADV5 QTY4	28002946	865/359	-	389 lm	400 mA	5.4 V	5.8 V	-	-	170 lm/W	> >80
LLE 24x140mm 650lm 830 HV ADV5	89603206	830/359	-	774 lm	400 mA	10.7 V	11.6 V	-	-	175 lm/W	> >80
LLE 24x140mm 650lm 835 HV ADV5	28003404	835/359	-	806 lm	400 mA	10.7 V	11.6 V	-	-	180 lm/W	> >80
LLE 24x140mm 650lm 840 HV ADV5	89603207	840/359	-	812 lm	400 mA	10.7 V	11.6 V	-	-	182 lm/W	> >80
LLE 24x280mm 1250lm 827 HV ADV5	89603210	827/359	-	1,502 lm	400 mA	21.5 V	23.2 V	-	-	167 lm/W	> >80
LLE 24x280mm 1250lm 830 HV ADV5	89603211	830/359	-	1,537 lm	400 mA	21.5 V	23.2 V	-	-	171 lm/W	> >80
LLE 24x280mm 1250lm 835 HV ADV5	28003405	835/359	-	1,613 lm	400 mA	21.5 V	23.2 V	-	-	177 lm/W	> >80
LLE 24x280mm 1250lm 840 HV ADV5	89603212	840/359	-	1,623 lm	400 mA	21.5 V	23.2 V	-	-	179 lm/W	> >80
LLE 24x280mm 1250lm 850 HV ADV5	89603213	850/359	-	1,601 lm	400 mA	21.5 V	23.2 V	-	-	177 lm/W	> >80
LLE 24x280mm 1250lm 865 HV ADV5	89603214	865/359	-	1,611 lm	400 mA	21.5 V	23.2 V	-	-	179 lm/W	> >80
LLE 24x560mm 2400lm 827 HV ADV5	89603215	827/359	-	2,959 lm	400 mA	42.9 V	46.4 V	-	-	166 lm/W	> >80
LLE 24x560mm 2400lm 830 HV ADV5	89603216	830/359	-	3,085 lm	400 mA	42.9 V	46.4 V	-	-	173 lm/W	> >80
LLE 24x560mm 2400lm 835 HV ADV5	28003262	835/359	-	3,145 lm	400 mA	42.9 V	46.4 V	-	-	176 lm/W	> >80
LLE 24x560mm 2400lm 840 HV ADV5	89603217	840/359	-	3,241 lm	400 mA	42.9 V	46.4 V	-	-	181 lm/W	> >80
LLE 24x560mm 2400lm 850 HV ADV5	89603218	850/359	-	3,188 lm	400 mA	42.9 V	46.4 V	-	-	178 lm/W	> >80
LLE 24x560mm 2400lm 865 HV ADV5	89603219	865/359	-	3,228 lm	400 mA	42.9 V	46.4 V	-	-	180 lm/W	> >80
Operating mode HO at 500 mA											
LLE 24x70mm 325lm 830 HV ADV5 QTY4	89603203	830/359	-	472 lm	500 mA	5.5 V	5.9 V	-	-	162 lm/W	> >80
LLE 24x70mm 325lm 840 HV ADV5 QTY4	89603204	840/359	-	486 lm	500 mA	5.5 V	5.9 V	-	-	169 lm/W	> >80
LLE 24x70mm 325lm 850 HV ADV5 QTY4	28003379	850/359	-	487 lm	500 mA	5.2 V	5.6 V	-	-	167 lm/W	> >80
LLE 24x70mm 325lm 865 HV ADV5 QTY4	28002946	865/359	-	469 lm	500 mA	5.5 V	5.9 V	-	-	164 lm/W	> >80
LLE 24x140mm 650lm 830 HV ADV5	89603206	830/359	-	940 lm	500 mA	10.9 V	11.8 V	-	-	167 lm/W	> >80
LLE 24x140mm 650lm 835 HV ADV5	28003404	835/359	-	977 lm	500 mA	10.9 V	11.8 V	-	-	172 lm/W	> >80
LLE 24x140mm 650lm 840 HV ADV5	89603207	830/359	-	982 lm	500 mA	10.9 V	11.8 V	-	-	174 lm/W	> >80
LLE 24x280mm 1250lm 827 HV ADV5	89603210	827/359	-	1,824 lm	500 mA	21.8 V	23.5 V	-	-	159 lm/W	> >80
LLE 24x280mm 1250lm 830 HV ADV5	89603211	830/359	-	1,866 lm	500 mA	21.8 V	23.5 V	-	-	163 lm/W	> >80
LLE 24x280mm 1250lm 835 HV ADV5	28003405	835/359	-	1,953 lm	500 mA	21.8 V	23.5 V	-	-	170 lm/W	> >80
LLE 24x280mm 1250lm 840 HV ADV5	89603212	840/359	-	1,973 lm	500 mA	21.8 V	23.5 V	-	-	172 lm/W	> >80
LLE 24x280mm 1250lm 850 HV ADV5	89603213	850/359	-	1,976 lm	500 mA	21.8 V	23.5 V	-	-	172 lm/W	> >80
LLE 24x280mm 1250lm 865 HV ADV5	89603214	865/359	-	1,958 lm	500 mA	21.8 V	23.5 V	-	-	172 lm/W	> >80
LLE 24x560mm 2400lm 827 HV ADV5	89603215	827/359	-	3,591 lm	500 mA	43.6 V	47.1 V	-	-	158 lm/W	> >80
LLE 24x560mm 2400lm 830 HV ADV5	89603216	830/359	-	3,750 lm	500 mA	43.6 V	47.1 V	-	-	165 lm/W	> >80
LLE 24x560mm 2400lm 835 HV ADV5	28003262	835/359	-	3,815 lm	500 mA	43.6 V	47.1 V	-	-	167 lm/W	> >80

Type	Article number	Photometric code	Useful luminous flux $\Phi_{v, tp} = 25^\circ\text{C}$	Expected luminous flux $\Phi_{v, tp}$ rated	Typ. forward current	Min. forward voltage at $I_{f, tp}$ rated	Max. forward voltage at $I_{f, tp} = 25^\circ\text{C}$	Power consumption P_{on} at $I_{f, tp} = 25^\circ\text{C}$	Efficacy of the module at $T_p = 25^\circ\text{C}$	Expected efficacy of the module at T_p rated	Colour rendering index CRI
LLE 24x560mm 2400lm 840 HV ADV5	89603217	840/359	-	3,935 lm	500 mA	43.6 V	47.1 V	-	-	173 lm/W	> >80
LLE 24x560mm 2400lm 850 HV ADV5	89603218	850/359	-	3,926 lm	500 mA	43.6 V	47.1 V	-	-	173 lm/W	> >80
LLE 24x560mm 2400lm 865 HV ADV5	89603219	865/359	-	3,940 lm	500 mA	43.6 V	47.1 V	-	-	173 lm/W	> >80

② If mounted with M4 screws and plastic washers.

③ Tolerance of useful light flux - 0 % / + 15 %. Measurement uncertainty $\pm 10\%$.

④ Tolerance of expected light flux - 0 % / + 15 %. Measurement uncertainty $\pm 10\%$. Based on calculation.

⑤ Measurement tolerance forward voltage: $\pm 0.1\text{V}$.

⑥ Tolerance of power consumption $P_{on} \pm 10\%$. Measurement uncertainty $\pm 5\%$.

LINEAR COVER LLE

Accessory

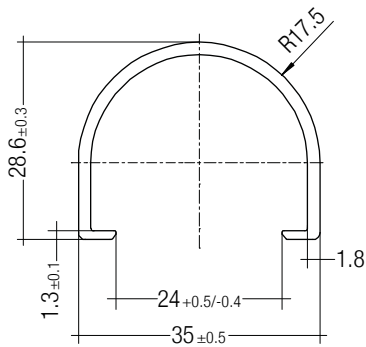

Product description

- _ LINEAR COVER for LLE
- _ Protection against direct touch for non-SELV applications (recommendation LLE 20: use all fixing points and screwed Endcap, recommendation LLE 24: use all fixing points)
- _ Fast snap on mounting on to LLE 20: with M4 screws and plastic washers, to LLE 24: with clips or plastic washers
- _ High transmission: transparent, semi-transparent and diffuse
- _ Material: PMMA
- _ Tolerances: ± 1 mm for 597 mm length (ends finished), + 10 mm from length 1,150 mm (ends raw)

Website

<http://www.tridonic.com/28000338>



Ordering data

Type	Article number	Colour	Length L	Efficiency	Packaging, carton	Weight per pc.
LINEAR COVER SY Transparent 1600mm	28000338	Transparent	1,600 mm	94 %	12 pc(s).	0.272 kg
LINEAR COVER SY Frosted 1800mm	28000437	Semi-transparent	1,800 mm	87 %	12 pc(s).	0.308 kg
LINEAR COVER SY Frosted 1600mm	28000339	Semi-transparent	1,600 mm	87 %	12 pc(s).	0.272 kg
LINEAR COVER SY Frosted 1500mm	28000435	Semi-transparent	1,500 mm	87 %	12 pc(s).	0.244 kg
LINEAR COVER SY Frosted 1200mm	28000422	Semi-transparent	1,200 mm	87 %	12 pc(s).	0.205 kg
LINEAR COVER SY Frosted 597mm	28000340	Semi-transparent	597 mm	87 %	12 pc(s).	0.102 kg
LINEAR COVER SY Diffuse 1800mm	28000438	Diffuse	1,800 mm	76 %	12 pc(s).	0.308 kg
LINEAR COVER SY Diffuse 1600mm	28000341	Diffuse	1,600 mm	76 %	12 pc(s).	0.272 kg
LINEAR COVER SY Diffuse 1500mm	28000436	Diffuse	1,500 mm	76 %	12 pc(s).	0.257 kg
LINEAR COVER SY Diffuse 1200mm	28000434	Diffuse	1,200 mm	76 %	12 pc(s).	0.205 kg
LINEAR COVER SY Diffuse 597mm	28000342	Diffuse	597 mm	76 %	12 pc(s).	0.102 kg

ACL ENDCAP LLE

Accessory

**Product description**

- _ ENDCAP for LLE
- _ PUSH-FIX: Fast snap on mounting (sheet thickness 0.5 – 1.0 mm), for drilling hole 4 mm
- _ SCREW-FIX: Screw mounting with EJOT Delta PT WN 5451 30x8 (not included), tightening torque 0.7 Nm
- _ Clip made of polycarbonate

Website

<http://www.tridonic.com/28001037>

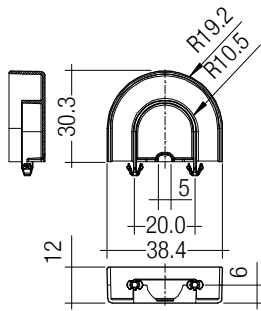
**Ordering data**

Type	Article number	Colour	Packaging, carton	Weight per pc.
ACL ENDCAP LLE24 PUSH-FIX	28001037	White	480 pc(s).	0.003 kg
ACL ENDCAP LLE24 SCREW-FIX	28002315	White	480 pc(s).	0.003 kg

ACL LINEAR LENS 24mm

Accessory

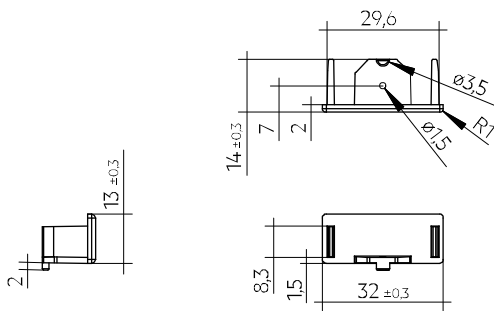
**Product description LINEAR LENS**

- _ Linear lens for LLE 20 / 24
- _ Available with different beam characteristics
- _ Protection against direct touch for non-SELV applications (recommendation: use all fixing points)
- _ Fast snap on mounting on to LLE 20: with M4 screws and plastic washers, to LLE 24: with clips or plastic washers
- _ Recommendation: Fastening with screws and plastic washers, see 2.3 Heat sink specifications in data sheet
- _ Material: PMMA
- _ Available lengths: 1,200, 1,500 and 1,800 mm, Tolerance: + 10 mm (ends raw)
- _ Max. permissible temperature 80 °C
- _ Photometric data available on website

Product description Endcap

- _ ENDCAP for LINEAR LENS 24mm INTENSE, ASY and DASY
- _ Mounting by clipping in and screwing from below using screw EJOT Delta PT WN 5451 20x4, tightening torque 0.7 Nm
- _ Made of Polyamide UL94 V0

Website

<http://www.tridonic.com/28001428>

**Ordering data**

Type	Article number	Length L	Beam characteristic	Efficiency	Packaging, carton	Weight per pc.
ACL LINEAR LENS 24x1200mm 60°	28001428	1,200 mm	60°	97 %	21 pc(s).	0.196 kg
ACL LINEAR LENS 24x1200mm 90°	28001429	1,200 mm	90°	97 %	21 pc(s).	0.165 kg
ACL LINEAR LENS 24x1500mm 60°	28000953	1,500 mm	60°	97 %	21 pc(s).	0.261 kg
ACL LINEAR LENS 24x1500mm 90°	28000955	1,500 mm	90°	97 %	21 pc(s).	0.221 kg
ACL LINEAR LENS 24x1200mm INTENSE	28002024	1,200 mm	40°	95 %	18 pc(s).	0.261 kg
ACL LINEAR LENS 24x1500mm INTENSE	28002025	1,500 mm	40°	95 %	18 pc(s).	0.326 kg
ACL LINEAR LENS 24x1800mm INTENSE	28002026	1,800 mm	40°	95 %	18 pc(s).	0.392 kg
ACL LINEAR LENS 24x1200mm BATWING	28002027	1,200 mm	batwing	95 %	18 pc(s).	0.275 kg
ACL LINEAR LENS 24x1500mm BATWING	28002028	1,500 mm	batwing	95 %	18 pc(s).	0.344 kg
ACL LINEAR LENS 24x1800mm BATWING	28002029	1,800 mm	batwing	95 %	18 pc(s).	0.412 kg
ACL LINEAR LENS 24x1200mm ASY	28002030	1,200 mm	asymmetric	95 %	18 pc(s).	0.250 kg
ACL LINEAR LENS 24x1500mm ASY	28002031	1,500 mm	asymmetric	95 %	18 pc(s).	0.312 kg
ACL LINEAR LENS 24x1800mm ASY	28002032	1,800 mm	asymmetric	95 %	18 pc(s).	0.375 kg
ACL LINEAR LENS 24x1200mm DASY	28002033	1,200 mm	double asymmetric	92 %	18 pc(s).	0.249 kg
ACL LINEAR LENS 24x1500mm DASY	28002034	1,500 mm	double asymmetric	92 %	18 pc(s).	0.311 kg
ACL LINEAR LENS 24x1800mm DASY	28002035	1,800 mm	double asymmetric	92 %	18 pc(s).	0.373 kg
ACL Endcap LENS 24mm PSF	28002669	-	-	-	3,600 pc(s).	0.003 kg

ACL CLIP 4.3mm

Accessory

**Product description**

- _ Clip for fixation of LED modules with 4.3 mm holes
- _ Fast snap on mounting (sheet thickness 0.5 – 1.0 mm for PUSH-FIX and 1 – 2 mm for PUSH-FIX Long)
- _ For drilling hole 4 mm
- _ Clip made of polycarbonate
- _ Minimum sales quantity 500 pcs.

Website

<http://www.tridonic.com/28001036>

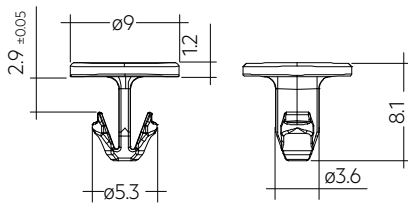
**Ordering data**

Type	Article number	Colour	Packaging, bag ^①	Weight per pc.
ACL CLIP 4.3mm PUSH-FIX	28001036	White	500 pc(s).	0.001 kg
ACL CLIP 4,3mm PUSH-FIX Long	28002314	Transparent	500 pc(s).	0.001 kg

① Minimum sales quantity 500 pcs.

ACL BRIDGE LLE24/40

Accessory

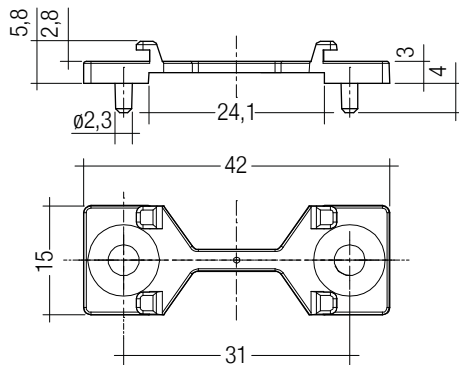
**Product description**

- _ Enables the fixation of 24 mm wide Tridonic LED modules to fixtures made for 40 mm wide modules
- _ Ideal for extruded aluminium gear trays made for 40 mm modules with pre-alignment knobs
- _ Clip-on for LINEAR COVER and LINEAR LENS ^①
- _ For LLE 24 with 280 mm module minimum 2 bridges required
- _ For LLE 24 with 560 mm module minimum 3 bridges required
- _ Fixation via M3 or M4 countersunk screw, max. tightening torque 0.5 Nm
- _ BRIDGE made of white polycarbonate
- _ Minimum sales quantity 600 pcs.

^① Beam characteristics will change due to the elevated fixation (see photometric files for details).

Website

<http://www.tridonic.com/28001205>

**Ordering data**

Type	Article number	Colour	Packaging, carton	Weight per pc.
ACL BRIDGE LLE24/40 SCREW-FIX	28001205	White	600 pc(s).	0.001 kg

1. Standards

IEC 62031
 IEC 62471
 IEC 61000-4-2
 IEC 62778
 IEC 61547
 UL 8750 (for CLASS2 circuits and dry locations)

1.1 Photometric code

Key for photometric code, e. g. 830 / 349

1 st digit	2 nd + 3 rd digit	4 th digit	5 th digit	6 th digit
Code CRI	Colour temperature in Kelvin x 100	MacAdam initial	MacAdam after 25% of the lifetime (max.6000h)	Luminous flux after 25% of the lifetime (max.6000h)
7 70 – 79				Code Luminous flux
8 80 – 89				7 ≥ 70 %
9 ≥90				8 ≥ 80 %
				9 ≥ 90 %

1.2 Energy classification

Type	Colour temperature	Forward current	Energy classification	Energy consumption
LLE 24x70mm 325lm 830 HV ADV5 QTY4	3,000 K	300 mA	C	2 kWh / 1,000 h
LLE 24x70mm 325lm 840 HV ADV5 QTY4	4,000 K	300 mA	C	2 kWh / 1,000 h
LLE 24x70mm 325lm 850 HV ADV5 QTY4	5,000 K	300 mA	C	2 kWh / 1,000 h
LLE 24x70mm 325lm 865 HV ADV5 QTY4	6,500 K	300 mA	C	2 kWh / 1,000 h
LLE 24x140mm 650lm 830 HV ADV5	3,000 K	300 mA	C	4 kWh / 1,000 h
LLE 24x140mm 650lm 835 HV ADV5	3,500 K	300 mA	C	4 kWh / 1,000 h
LLE 24x140mm 650lm 840 HV ADV5	4,000 K	300 mA	C	4 kWh / 1,000 h
LLE 24x280mm 1250lm 827 HV ADV5	2,700 K	300 mA	C	7 kWh / 1,000 h
LLE 24x280mm 1250lm 830 HV ADV5	3,000 K	300 mA	C	7 kWh / 1,000 h
LLE 24x280mm 1250lm 835 HV ADV5	3,500 K	300 mA	C	7 kWh / 1,000 h
LLE 24x280mm 1250lm 840 HV ADV5	4,000 K	300 mA	C	7 kWh / 1,000 h
LLE 24x280mm 1250lm 850 HV ADV5	5,000 K	300 mA	C	7 kWh / 1,000 h
LLE 24x280mm 1250lm 865 HV ADV5	6,500 K	300 mA	C	7 kWh / 1,000 h
LLE 24x560mm 2400lm 827 HV ADV5	2,700 K	300 mA	D	14 kWh / 1,000 h
LLE 24x560mm 2400lm 830 HV ADV5	3,000 K	300 mA	C	14 kWh / 1,000 h
LLE 24x560mm 2400lm 835 HV ADV5	3,500 K	300 mA	C	14 kWh / 1,000 h
LLE 24x560mm 2400lm 840 HV ADV5	4,000 K	300 mA	C	14 kWh / 1,000 h
LLE 24x560mm 2400lm 850 HV ADV5	5,000 K	300 mA	C	14 kWh / 1,000 h
LLE 24x560mm 2400lm 865 HV ADV5	6,500 K	300 mA	C	14 kWh / 1,000 h

Energy label and further information at www.tridonic.com in the certificates tab of the corresponding product page and at the EPREL data base <https://eprel.ec.europa.eu/>

2. Thermal details

2.1 tc point, ambient temperature and lifetime

The temperature at tp reference point is crucial for the light output and lifetime of a LED product.

For LLE a tp temperature of 50 °C has to be complied in order to achieve an optimum between heat sink requirements, light output and lifetime.

Compliance with the maximum permissible reference temperature at the tc point must be checked under operating conditions in a thermally stable state. The maximum value must be determined under worst-case conditions for the relevant application.

The tc and tp temperature of LED modules from Tridonic are measured at the same reference point.

2.2 Storage and humidity

Storage temperature	-40...+80 °C
---------------------	--------------

Operation only in non condensing environment.

Humidity during processing of the module should be between 30 to 70 %.

2.3 Heat sink values

LLE 24x70mm 325lm ADV5

ta	tp	Forward current	R _{th, hs-a}	Cooling area
25 °C	50 °C	300 mA	2897 K/W	23 cm ²
25 °C	50 °C	500 mA	1721 K/W	39 cm ²
35 °C	50 °C	300 mA	1737 K/W	38 cm ²
35 °C	50 °C	500 mA	1032 K/W	65 cm ²
40 °C	50 °C	300 mA	1157 K/W	58 cm ²
40 °C	50 °C	500 mA	687 K/W	97 cm ²
45 °C	50 °C	300 mA	577 K/W	115 cm ²
45 °C	50 °C	500 mA	342 K/W	195 cm ²

LLE 24x140mm 650lm ADV5

ta	tp	Forward current	R _{th, hs-a}	Cooling area
25 °C	50 °C	300 mA	1449 K/W	46 cm ²
25 °C	50 °C	500 mA	861 K/W	77 cm ²
35 °C	50 °C	300 mA	869 K/W	77 cm ²
35 °C	50 °C	500 mA	516 K/W	129 cm ²
40 °C	50 °C	300 mA	579 K/W	115 cm ²
40 °C	50 °C	500 mA	343 K/W	194 cm ²
45 °C	50 °C	300 mA	289 K/W	231 cm ²
45 °C	50 °C	500 mA	171 K/W	390 cm ²

LLE 24x280mm 1250lm ADV5

ta	tp	Forward current	R _{th, hs-a}	Cooling area
25 °C	50 °C	300 mA	725 K/W	92 cm ²
25 °C	50 °C	500 mA	430 K/W	155 cm ²
35 °C	50 °C	300 mA	435 K/W	153 cm ²
35 °C	50 °C	500 mA	258 K/W	259 cm ²
40 °C	50 °C	300 mA	290 K/W	230 cm ²
40 °C	50 °C	500 mA	172 K/W	388 cm ²
45 °C	50 °C	300 mA	144 K/W	462 cm ²
45 °C	50 °C	500 mA	085 K/W	780 cm ²

LLE 24x560mm 2400lm ADV5

ta	tp	Forward current	R _{th, hs-a}	Cooling area
25°C	50°C	300 mA	3.62 K/W	184 cm ²
25°C	50°C	500 mA	2.15 K/W	310 cm ²
35°C	50°C	300 mA	2.17 K/W	307 cm ²
35°C	50°C	500 mA	1.29 K/W	517 cm ²
40°C	50°C	300 mA	1.45 K/W	460 cm ²
40°C	50°C	500 mA	0.86 K/W	776 cm ²
45°C	50°C	300 mA	0.72 K/W	923 cm ²
45°C	50°C	500 mA	0.43 K/W	1,559 cm ²

Notes

The actual cooling surface can differ because of the material, the structural shape, outside influences and the installation situation. Depending on the heat sink a heat conducting paste or heat conducting film might be necessary to keep the specified tp temperature.

3. Installation / wiring**3.1 Electrical supply/choice of LED driver**

LLE modules from Tridonic are not protected against overvoltages, overcurrents, overloads or short-circuit currents. Safe and reliable operation can only be guaranteed in conjunction with a LED driver which complies with the relevant standards. The use of LED driver from Tridonic in combination with LLE modules guarantees the necessary protection for safe and reliable operation.

If a LED driver other than Tridonic is used, it must provide the following protection:

- Short-circuit protection
- Overload protection
- Overtemperature protection



LLE modules must be supplied by a constant current LED driver. Operation with a constant voltage LED driver will lead to an irreversible damage of the module.

Wrong polarity can damage the LLE.

The LLE module is designed for serial wiring.

With parallel wiring tolerance-related differences in output are possible (thermal stress of the module) and can cause differences in brightness.

If a wire breaks or a complete module fails then the current passing through the other module increases. This may reduce its life considerably.

Max. 8 pieces 280 mm modules or 4 pieces 560 mm modules may be connected in parallel.

LLE can be operated either from SELV LED drivers or from LED drivers with LV output voltage.



LLE are basic insulated up to 440 V (if mounted with M4 screws with head diameter 7 mm in combination with plastic washers) against ground and can be mounted directly on earthed metal parts of the luminaire. If the max. output voltage of the LED driver (also against earth) is above 440 V, an additional insulation between LED module and heat sink is required (for example by insulated thermal pads) or by a suitable luminaire construction.

At voltages > 60 V an additional protection against direct touch (test finger) to the light emitting side of the module has to be guaranteed. This is typically achieved by means of a non removable light distributor over the module.

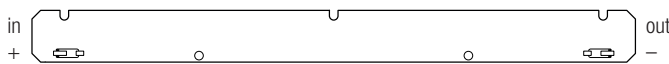
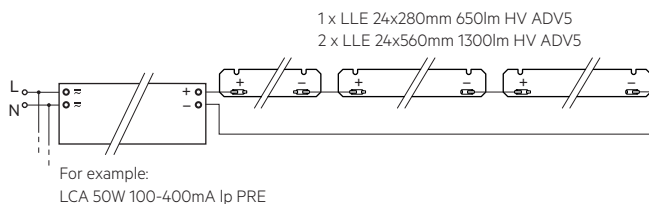
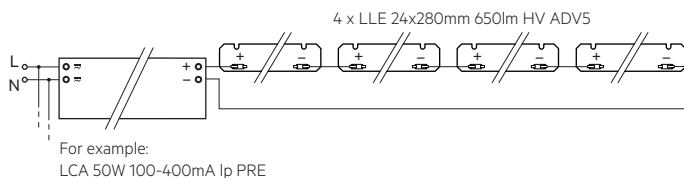
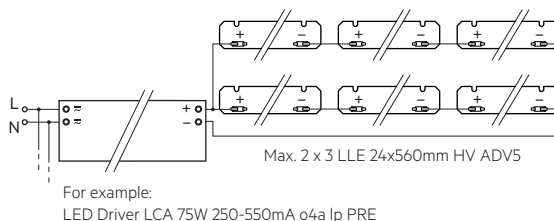
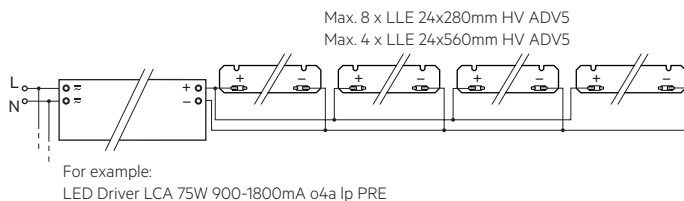
3.2 Wiring**Wiring examples for serial wiring****Wiring examples for parallel wiring****3.3 Wiring type and cross section**

For wiring use stranded wire with ferrules or solid wire from 0.2 to 0.75 mm². For the push-wire connection you have to strip the insulation (8–9 mm).

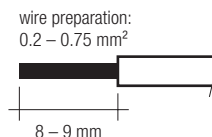

To remove the wires use a suitable tool (e.g. Microcon release pin) or through twist and pull.

3.4 Mounting instruction



None of the components of the LLE (substrate, LED, electronic components etc.) may be exposed to tensile or compressive stresses.

Max. torque for fixing: 0.5 Nm.

The LED modules are mounted onto a heat sink with min. 3 screws per module or ACL CLIP 4.3mm.

The LLE 24x70mm module is delivered as a board of 280mm (4 pcs.) and must be separated.

Only touch the module at the edge to separate the modules (see marking below).

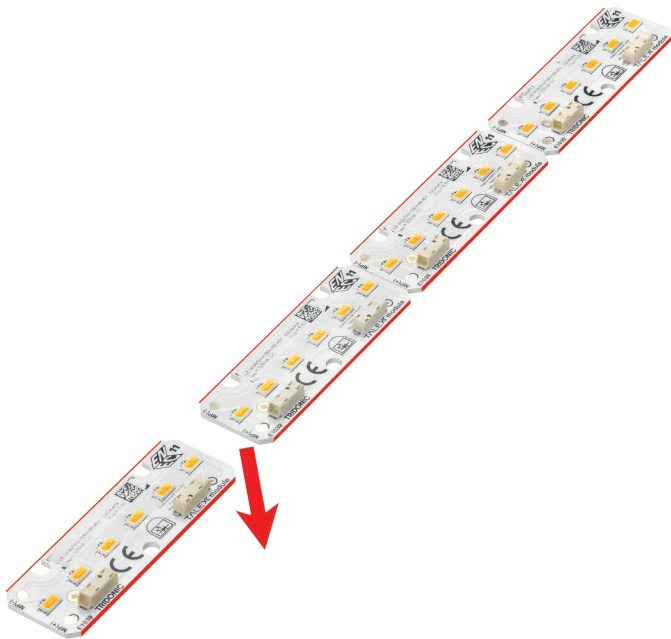

Cut out on gear tray for backside terminal:

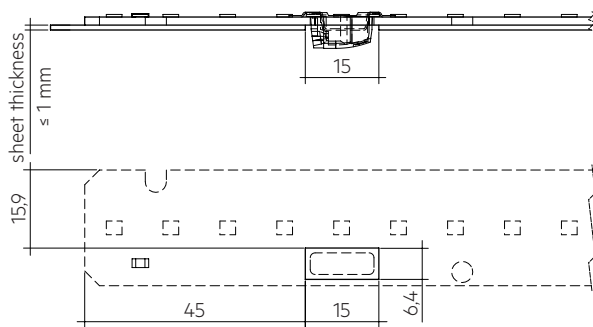

Chemical substance may harm the LED module. Chemical reactions could lead to colour shift, reduced luminous flux or a total failure of the module caused by corrosion of electrical connections.

Materials which are used in LED applications (e.g. sealings, adhesives) must not produce dissolver gas. They must not be condensation curing based, acetate curing based or contain sulfur, chlorine or phthalate.

Avoid corrosive atmosphere during usage and storage.

3.5 EOS/ESD safety guidelines



The device / module contains components that are sensitive to electrostatic discharge and may only be installed in the factory and on site if appropriate EOS/ESD protection measures have been taken. No special measures need be taken for devices/modules with enclosed casings (contact with the pc board not possible), just normal installation practice. Please note the requirements set out in the document EOS / ESD guidelines (Guideline_EOS_ESD.pdf) at: <http://www.tridonic.com/esd-protection>

4. Lifetime

4.1 Lifetime, lumen maintenance and failure rate

The light output of an LED module decreases over the lifetime, this is characterized with the L value.

L70 means that the LED module will give 70 % of its initial luminous flux.

This value is always related to the number of operation hours and therefore defines the lifetime of an LED module.

As the L value is a statistical value and the lumen maintenance may vary over the delivered LED modules.

The B value defines the amount of modules which are below the specific L value, e.g. L70B10 means 10 % of the LED modules are below 70 % of the initial luminous flux, respectively 90 % will be above 70 % of the initial value.

In addition the percentage of failed modules (fatal failure) is characterized by the C value.

The F value is the combination of the B and C value. That means for F degradation and complete failures are considered, e.g. L70F10 means 10 % of the LED modules may fail or be below 70 % of the initial luminous flux.

4.2 Lumen maintenance for LLE 24mm HV ADV5

Forward current	tp tempera- ture	L90 / F10	L90 / F50	L80 / F10	L80 / F50	L70 / F10	L70 / F50	
								40 °C
150 mA	45 °C	42,000 h	57,000 h	>72,000 h	>72,000 h	>72,000 h	>72,000 h	
	50 °C	41,000 h	55,000 h	>72,000 h	>72,000 h	>72,000 h	>72,000 h	
	55 °C	40,000 h	54,000 h	>72,000 h	>72,000 h	>72,000 h	>72,000 h	
	60 °C	39,000 h	52,000 h	>72,000 h	>72,000 h	>72,000 h	>72,000 h	
	65 °C	38,000 h	50,000 h	>72,000 h	>72,000 h	>72,000 h	>72,000 h	
	70 °C	38,000 h	49,000 h	>72,000 h	>72,000 h	>72,000 h	>72,000 h	
	75 °C	37,000 h	47,000 h	>72,000 h	>72,000 h	>72,000 h	>72,000 h	
	80 °C	36,000 h	46,000 h	>72,000 h	>72,000 h	>72,000 h	>72,000 h	
	85 °C	35,000 h	45,000 h	>72,000 h	>72,000 h	>72,000 h	>72,000 h	
	200 mA	40 °C	43,000 h	58,000 h	>72,000 h	>72,000 h	>72,000 h	>72,000 h
		45 °C	42,000 h	57,000 h	>72,000 h	>72,000 h	>72,000 h	>72,000 h
		50 °C	41,000 h	55,000 h	>72,000 h	>72,000 h	>72,000 h	>72,000 h
55 °C		40,000 h	53,000 h	>72,000 h	>72,000 h	>72,000 h	>72,000 h	
60 °C		39,000 h	51,000 h	>72,000 h	>72,000 h	>72,000 h	>72,000 h	
65 °C		38,000 h	50,000 h	>72,000 h	>72,000 h	>72,000 h	>72,000 h	
70 °C		37,000 h	48,000 h	>72,000 h	>72,000 h	>72,000 h	>72,000 h	
75 °C		36,000 h	47,000 h	>72,000 h	>72,000 h	>72,000 h	>72,000 h	
80 °C		36,000 h	45,000 h	>72,000 h	>72,000 h	>72,000 h	>72,000 h	
85 °C		35,000 h	44,000 h	>72,000 h	>72,000 h	>72,000 h	>72,000 h	
300 mA		40 °C	42,000 h	58,000 h	>72,000 h	>72,000 h	>72,000 h	>72,000 h
		45 °C	41,000 h	56,000 h	>72,000 h	>72,000 h	>72,000 h	>72,000 h
	50 °C	40,000 h	54,000 h	>72,000 h	>72,000 h	>72,000 h	>72,000 h	
	55 °C	40,000 h	52,000 h	>72,000 h	>72,000 h	>72,000 h	>72,000 h	
	60 °C	39,000 h	51,000 h	>72,000 h	>72,000 h	>72,000 h	>72,000 h	
	65 °C	38,000 h	49,000 h	>72,000 h	>72,000 h	>72,000 h	>72,000 h	
	70 °C	37,000 h	48,000 h	>72,000 h	>72,000 h	>72,000 h	>72,000 h	
	75 °C	36,000 h	46,000 h	>72,000 h	>72,000 h	>72,000 h	>72,000 h	
	80 °C	35,000 h	45,000 h	>72,000 h	>72,000 h	>72,000 h	>72,000 h	
	85 °C	34,000 h	44,000 h	70,000 h	>72,000 h	>72,000 h	>72,000 h	

Forward current	tp tempera- ture	L90 / F10	L90 / F50	L80 / F10	L80 / F50	L70 / F10	L70 / F50	
								40 °C
375 mA	45 °C	41,000 h	55,000 h	>72,000 h	>72,000 h	>72,000 h	>72,000 h	
	50 °C	40,000 h	54,000 h	>72,000 h	>72,000 h	>72,000 h	>72,000 h	
	55 °C	39,000 h	52,000 h	>72,000 h	>72,000 h	>72,000 h	>72,000 h	
	60 °C	38,000 h	50,000 h	>72,000 h	>72,000 h	>72,000 h	>72,000 h	
	65 °C	37,000 h	49,000 h	>72,000 h	>72,000 h	>72,000 h	>72,000 h	
	70 °C	37,000 h	47,000 h	>72,000 h	>72,000 h	>72,000 h	>72,000 h	
	75 °C	36,000 h	46,000 h	>72,000 h	>72,000 h	>72,000 h	>72,000 h	
	80 °C	35,000 h	44,000 h	71,000 h	>72,000 h	>72,000 h	>72,000 h	
	85 °C	34,000 h	43,000 h	69,000 h	>72,000 h	>72,000 h	>72,000 h	
	450 mA	40 °C	42,000 h	56,000 h	>72,000 h	>72,000 h	>72,000 h	>72,000 h
		45 °C	41,000 h	55,000 h	>72,000 h	>72,000 h	>72,000 h	>72,000 h
		50 °C	40,000 h	53,000 h	>72,000 h	>72,000 h	>72,000 h	>72,000 h
55 °C		39,000 h	51,000 h	>72,000 h	>72,000 h	>72,000 h	>72,000 h	
60 °C		38,000 h	50,000 h	>72,000 h	>72,000 h	>72,000 h	>72,000 h	
65 °C		37,000 h	48,000 h	>72,000 h	>72,000 h	>72,000 h	>72,000 h	
70 °C		36,000 h	47,000 h	>72,000 h	>72,000 h	>72,000 h	>72,000 h	
75 °C		35,000 h	45,000 h	>72,000 h	>72,000 h	>72,000 h	>72,000 h	
80 °C		35,000 h	44,000 h	70,000 h	>72,000 h	>72,000 h	>72,000 h	
85 °C		34,000 h	43,000 h	69,000 h	>72,000 h	>72,000 h	>72,000 h	
500 mA		40 °C	41,000 h	56,000 h	>72,000 h	>72,000 h	>72,000 h	>72,000 h
		45 °C	40,000 h	54,000 h	>72,000 h	>72,000 h	>72,000 h	>72,000 h
	50 °C	39,000 h	52,000 h	>72,000 h	>72,000 h	>72,000 h	>72,000 h	
	55 °C	38,000 h	51,000 h	>72,000 h	>72,000 h	>72,000 h	>72,000 h	
	60 °C	38,000 h	49,000 h	>72,000 h	>72,000 h	>72,000 h	>72,000 h	
	65 °C	37,000 h	48,000 h	>72,000 h	>72,000 h	>72,000 h	>72,000 h	
	70 °C	36,000 h	46,000 h	>72,000 h	>72,000 h	>72,000 h	>72,000 h	
	75 °C	35,000 h	45,000 h	71,000 h	>72,000 h	>72,000 h	>72,000 h	
	80 °C	34,000 h	43,000 h	70,000 h	>72,000 h	>72,000 h	>72,000 h	
	85 °C	34,000 h	42,000 h	68,000 h	>72,000 h	>72,000 h	>72,000 h	

4.3 Switching capability

100,000 cycles

Tridonic test according to IEC 62717 Cl 10.3.3

30 s on / 30 s off at I_{max}

5. Electrical values

5.1 Declaration of electrical parameters

Irated ... Nominal operating current the module is designed for.

I_{max} ... Max. permissible continuous operating current incl. The tolerances of the LED driver.

Max. permissible LF current ripple ... Max. output current of the LED driver incl. Tolerances and LF current ripple must not exceed this value.

Max. permissible peak current ... The max. output peak current of the LED driver must not exceed this value.

5.2 Typ. forward voltage vs. forward current

LLE 24x70mm 325lm 8xx HV ADV5

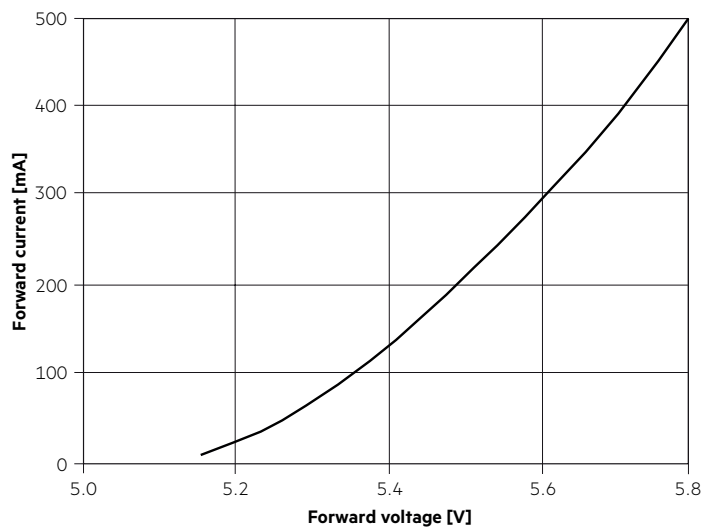

LLE 24x140mm 650lm 8xx HV ADV5

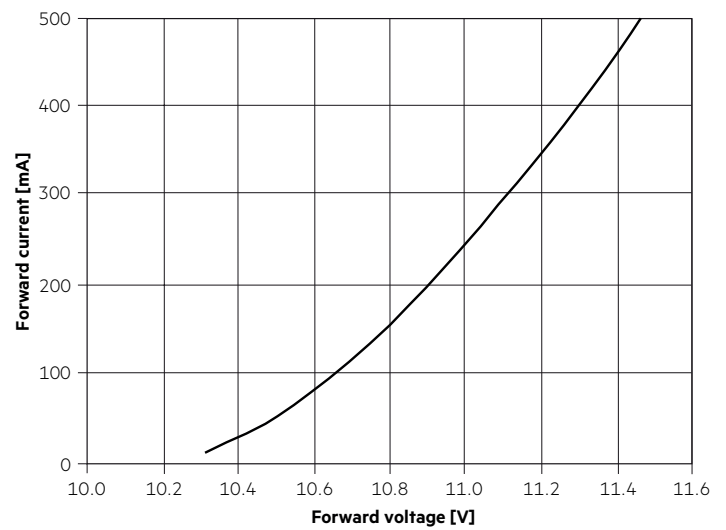

LLE 24x280mm 1250lm 8xx HV ADV5

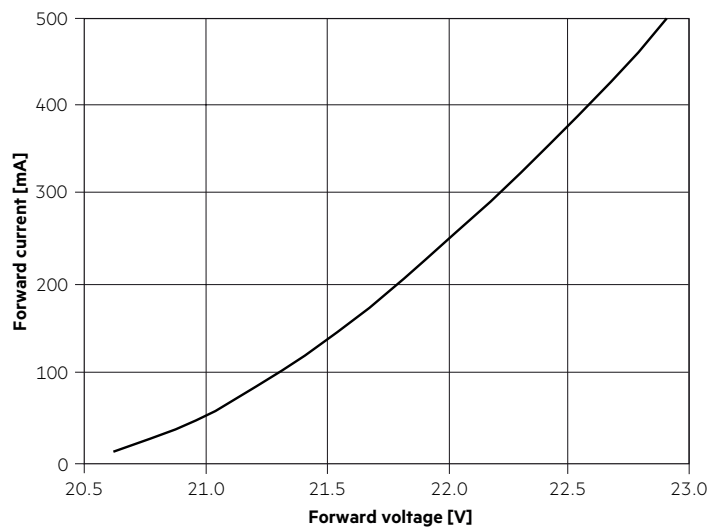

LLE 24x560mm 2400lm 8xx HV ADV5

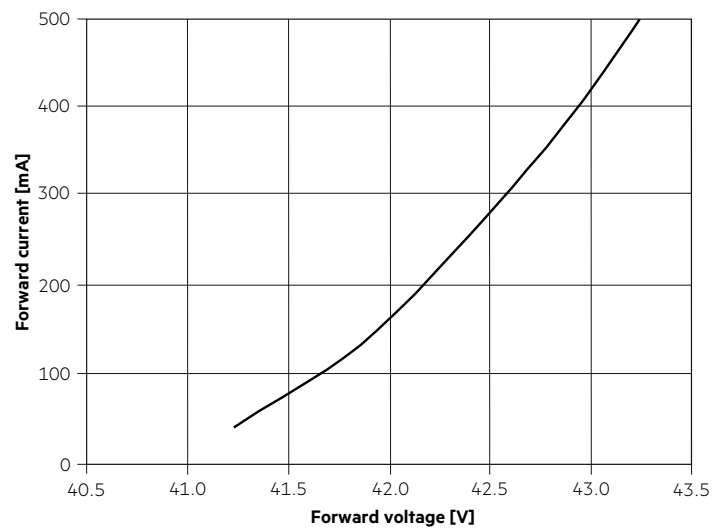

The diagrams are based on statistic values.
The real values can be different.

5.3 Forward voltage vs. t_c temperature

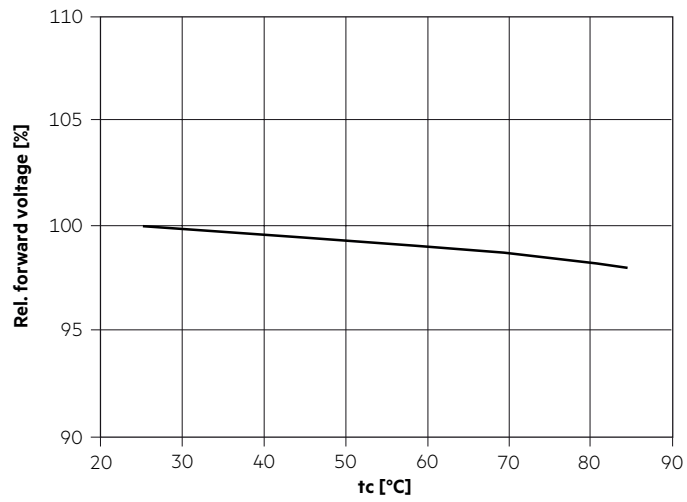

The diagrams are based on statistic values.
The real values can be different.

6. Photometric characteristics

6.1 Coordinates and tolerances according to CIE 1931

The specified colour coordinates are integral measured by current impulse of 195 mA and a duration of 100 ms.
 The ambient temperature of the measurement is $t_a = 25^\circ\text{C}$.
 The measurement tolerance of the colour coordinates are ± 0.01 .

2,700 K

	x0	y0
Centre	0.4578	0.4101

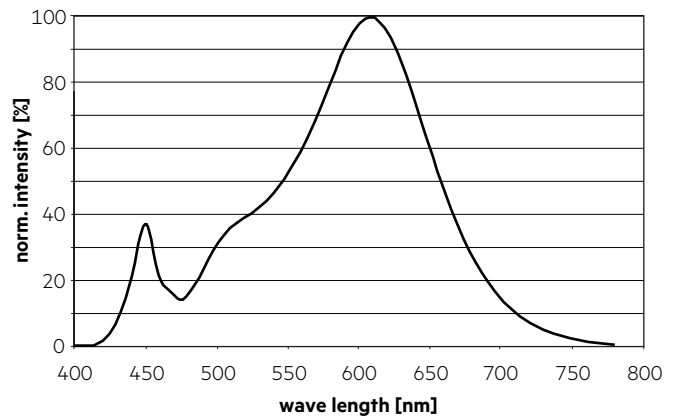
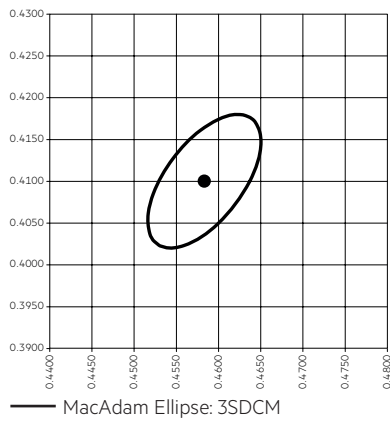

3,000 K

	x0	y0
Centre	0.4338	0.4030

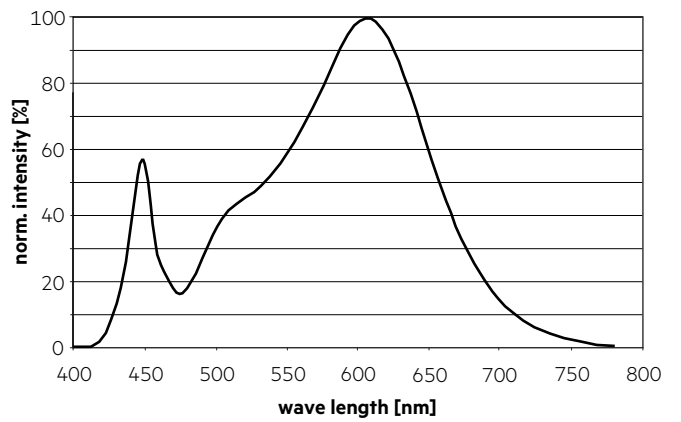
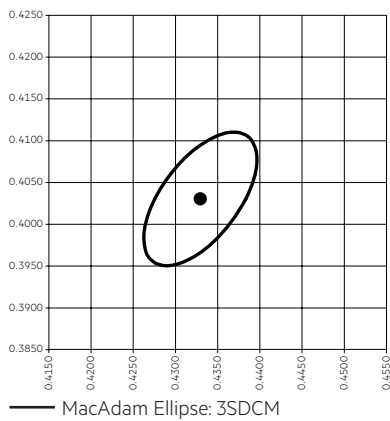

3,500 K

	x0	y0
Centre	0.4073	0.3917

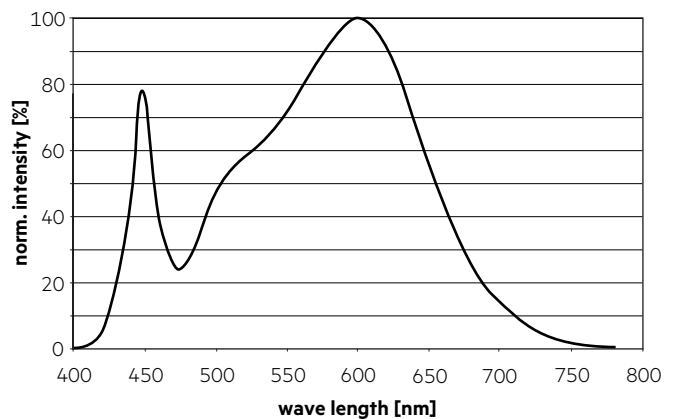
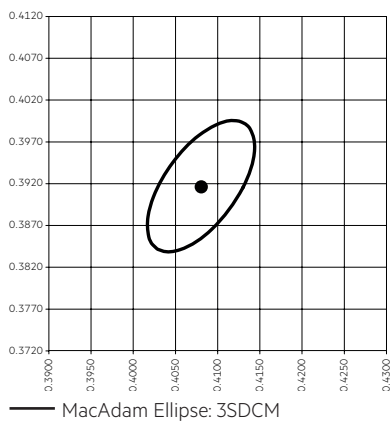

4,000 K

	x0	y0
Center	0.3818	0.3797

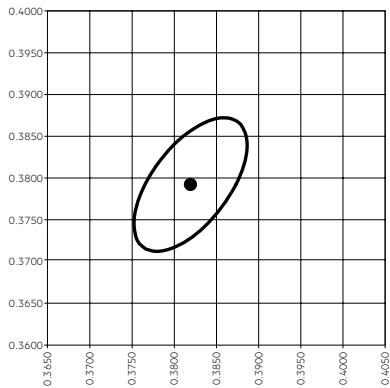

— MacAdam Ellipse: 3SDCM

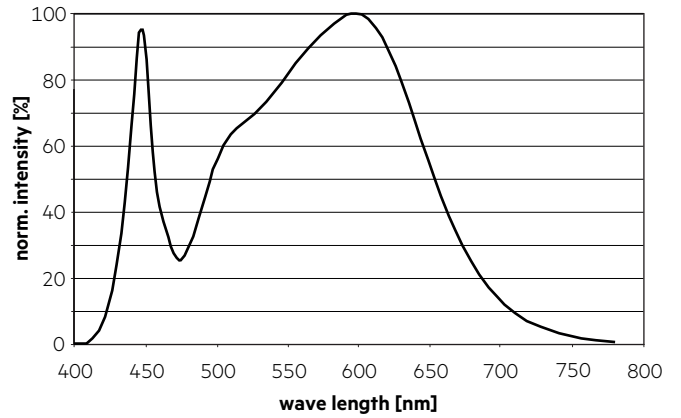

5,000 K

	x0	y0
Center	0.3447	0.3553

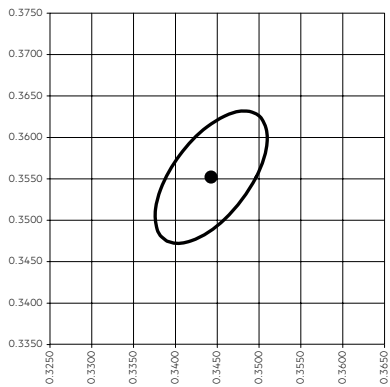

— MacAdam Ellipse: 3SDCM

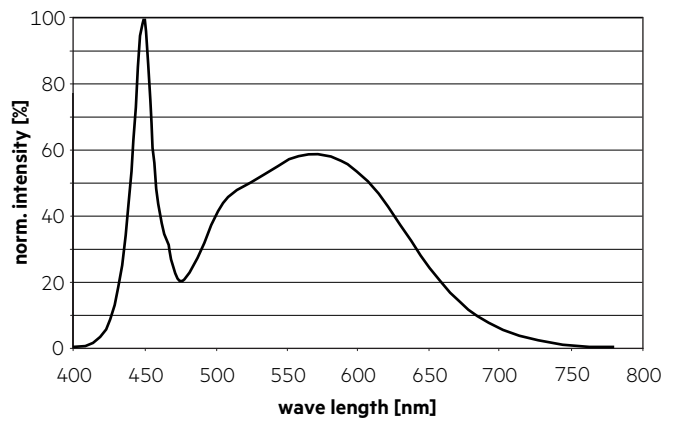

6,500 K

	x0	y0
Center	0.3123	0.3282

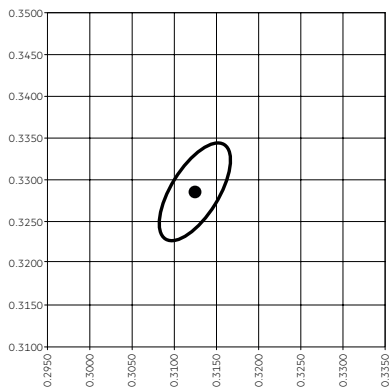

— MacAdam Ellipse: 3SDCM

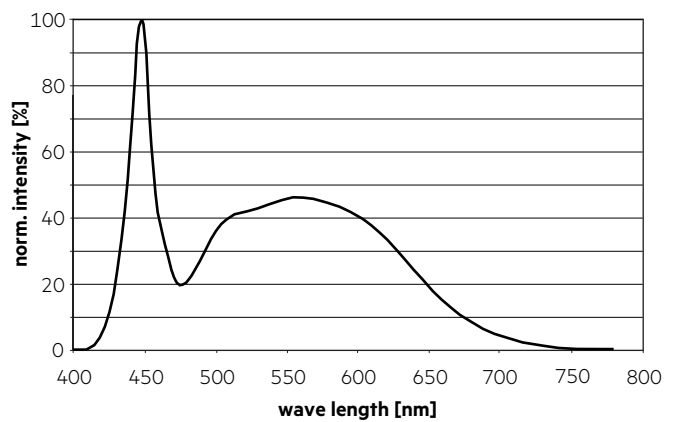

6.2 Light distribution

The optical design of the LLE product line ensures optimum homogeneity for the light distribution.

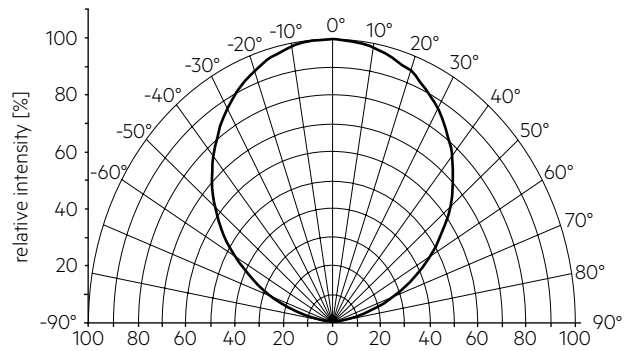

The colour temperature is measured integral over the complete module. The single LED light points can have deviations in the colour coordinates within MacAdam 5.

To ensure an ideal mixture of colours and a homogeneous light distribution a suitable optic (e. g. PMMA diffuser) and a sufficient spacing between module and optic (typ. 4 cm) should be used.

6.3 Relative luminous flux vs. tc temperature

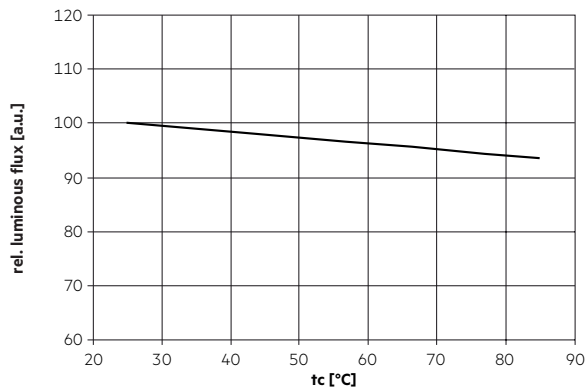

6.4 Relative luminous flux vs. operating current

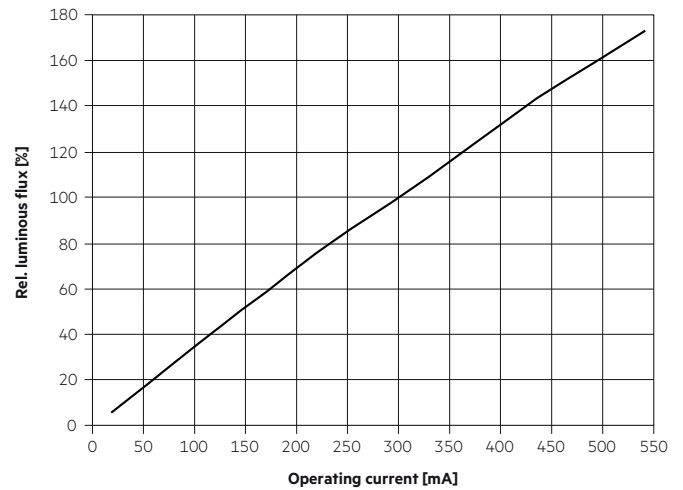

The diagrams are based on statistic values.
The real values can be different.

7. Miscellaneous

7.1 Additional information

Additional technical information at www.tridonic.com → Technical Data

Guarantee conditions at www.tridonic.com → Services

Lifetime declarations are informative and represent no warranty claim.